

***S,S*-1,2-Dicyclohexylethane-1,2-diol and its racemic compound: a striking exception to Wallach's rule****Brian O. Patrick and  
Carolyn Pratt Brock\***Department of Chemistry, University of  
Kentucky, Lexington, KY 40506-0055, USA

Correspondence e-mail: cpbrock@uky.edu

Received 29 September 2005

Accepted 5 January 2006

The structures of enantiopure *S,S*-1,2-dicyclohexylethane-1,2-diol and its racemic compound (*rac-S,S*-1,2-dicyclohexylethane-1,2-diol) have been determined at 295 and 173 K. The crystals of the enantiopure material are more than 4% denser than the crystals of the racemic compound, but the melting points indicate that the crystals of the less dense racemic compound are considerably more stable than those of the racemic conglomerate. This apparent exception to the correlation of crystal density and melting point is explained. The enantiopure crystals have four molecules in the asymmetric unit ( $Z' = 4$ ). Two of the molecules have the conformation observed for the one independent molecule of the racemic compound and two have a higher energy conformation; the overall  $P2_1$  structure is a perturbed version of a  $P2_12_12_1$  structure with  $Z' = 2$ . The enantiopure and racemic crystals have the same hydrogen-bonding motif, but the motif in the former appears to be significantly strained. A reason why crystals of enantiopure material might be systematically less dense than crystals of its racemic compound and to be more likely to have  $Z' > 1$  is suggested.

**1. Introduction**

Wallach's Rule<sup>1</sup> (see Brock *et al.*, 1991, and references therein) states that crystals of racemic compounds (*i.e.* 1:1 co-crystals of separable enantiomers) are usually denser than crystals of their enantiomerically pure counterparts. Crystals of racemic 1,2-dicyclohexylethane-1,2-diol, however, are 4.5% less dense at 295 K than crystals of the pure *S,S* (or the pure *R,R*) compound. At 173 K the difference is 4.6%. Density is usually correlated with stability, but the crystals of the racemic compound have a melting point that is *ca* 10 K higher than the melting point of the enantiopure material.

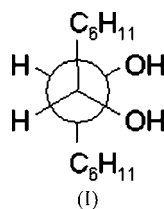

The difference in melting behavior is actually much greater than is implied by the  $T_{\text{fus}}$  values (408–409 and 420 K), because it is the eutectic temperature of the *R,R/S,S* racemic conglomerate (*i.e.* of the 1:1 mixture of enantiopure *R,R* and

<sup>1</sup> The statement of this rule actually occurs in an appendix to Wallach's (1895) paper. Since the appendix was written by Th. Liebig, Wallach's Rule is sometimes called Liebig's Rule (Kipping & Pope, 1897) or Liebig's Law (Flack, 2003). Note that the Rule, while true, is not predictive (see Brock *et al.*, 1991).

**Table 1**  
Experimental details.

	S,S, 295 K	S,S, 173 K	rac, 295 K	rac, 173 K
Crystal data				
Chemical formula	C <sub>14</sub> H <sub>26</sub> O <sub>2</sub>	C <sub>14</sub> H <sub>26</sub> O <sub>2</sub>	C <sub>14</sub> H <sub>26</sub> O <sub>2</sub>	C <sub>14</sub> H <sub>26</sub> O <sub>2</sub>
<i>M<sub>r</sub></i>	226.35	226.35	226.35	226.35
Cell setting, space group	Monoclinic, <i>P</i> 12 <sub>1</sub> 1	Monoclinic, <i>P</i> 12 <sub>1</sub> 1	Monoclinic, <i>C</i> 12/c1	Monoclinic, <i>C</i> 12/c1
<i>a</i> , <i>b</i> , <i>c</i> (Å)	5.540 (1), 41.653 (6), 12.025 (2)	5.4816 (6), 41.262 (6), 11.954 (2)	23.153 (5), 11.852 (3), 10.926 (2)	23.161 (5), 11.584 (3), 10.973 (2)
β (°)	90.33 (1)	90.39 (1)	104.64 (2)	106.10 (2)
<i>V</i> (Å <sup>3</sup> )	2774.8 (8)	2703.7 (7)	2900.9 (11)	2828.6 (11)
<i>Z</i>	8	8	8	8
<i>D<sub>x</sub></i> (Mg m <sup>-3</sup> )	1.084	1.112	1.037	1.063
Radiation type	Mo <i>K</i> α	Mo <i>K</i> α	Mo <i>K</i> α	Mo <i>K</i> α
No. of reflections for cell parameters	41 711	39 527	13 065	9027
θ range (°)	1.0–25.0	1.0–25.0	1.7–25.0	1.0–25.0
μ (mm <sup>-1</sup> )	0.07	0.07	0.07	0.07
Temperature (K)	295 (1)	173 (2)	295 (1)	173 (1)
Crystal form, colour	Needles; long axis is <i>a</i> . Prism faces are 010 and 001, colourless	Needles; long axis is <i>a</i> . Prism faces are 010 and 001, colourless	Laths; largest faces are 100; long direction is <i>c</i> , colourless	Laths; largest faces are 100; long direction is <i>c</i> , colourless
Crystal size (mm)	0.50 × 0.32 × 0.25	0.44 × 0.20 × 0.16	0.31 × 0.22 × 0.13	0.56 × 0.55 × 0.10
Data collection				
Diffractometer	Nonius Kappa-CCD	Nonius Kappa-CCD	Nonius Kappa-CCD	Nonius Kappa-CCD
Data collection method	φ and ω scans with 1.0° steps	φ and ω scans with 0.4° steps	φ and ω scans with 1.0° steps	φ and ω scans with 2.0° steps
Absorption correction	None	None	None	None
No. of measured, independent and observed reflections	9310, 4928, 3636	8305, 4720, 3750	4869, 2529, 1942	4693, 2489, 1911
Criterion for observed reflections	<i>I</i> > 2σ( <i>I</i> )	<i>I</i> > 2σ( <i>I</i> )	<i>I</i> > 2σ( <i>I</i> )	<i>I</i> > 2σ( <i>I</i> )
<i>R</i> <sub>int</sub>	0.047	0.034	0.023	0.021
θ <sub>max</sub> (°)	25.0	25.0	25.0	25.0
Absorption correction	None	None	None	None
Range of <i>h</i> , <i>k</i> , <i>l</i>	0 ⇒ <i>h</i> ⇒ 6 -48 ⇒ <i>k</i> ⇒ 49 -14 ⇒ <i>l</i> ⇒ 14	-6 ⇒ <i>h</i> ⇒ 6 -48 ⇒ <i>k</i> ⇒ 48 -14 ⇒ <i>l</i> ⇒ 14	-26 ⇒ <i>h</i> ⇒ 27 -14 ⇒ <i>k</i> ⇒ 14 -12 ⇒ <i>l</i> ⇒ 0	-27 ⇒ <i>h</i> ⇒ 27 -13 ⇒ <i>k</i> ⇒ 13 -13 ⇒ <i>l</i> ⇒ 13
Refinement				
Refinement on	<i>F</i> <sup>2</sup>	<i>F</i> <sup>2</sup>	<i>F</i> <sup>2</sup>	<i>F</i> <sup>2</sup>
<i>R</i> [ <i>F</i> <sup>2</sup> > 2σ( <i>F</i> <sup>2</sup> )], <i>wR</i> ( <i>F</i> <sup>2</sup> ), <i>S</i>	0.056, 0.144, 1.09	0.042, 0.089, 1.03	0.067, 0.207, 1.12	0.046, 0.116, 1.07
No. of reflections	4928	4720	2529	2489
No. of parameters	610	609	211	211
H-atom treatment	Mixture of independent and constrained refinement	Mixture of independent and constrained refinement	Mixture of independent and constrained refinement	Mixture of independent and constrained refinement
Weighting scheme	<i>w</i> = 1/[σ <sup>2</sup> ( <i>F</i> <sub>o</sub> <sup>2</sup> ) + (0.0680) <sup>2</sup> + 0.4 <i>P</i> ], where <i>P</i> = ( <i>F</i> <sub>o</sub> <sup>2</sup> + 2 <i>F</i> <sub>c</sub> <sup>2</sup> )/3	<i>w</i> = 1/[σ <sup>2</sup> ( <i>F</i> <sub>o</sub> <sup>2</sup> ) + (0.042) <sup>2</sup> ], where <i>P</i> = ( <i>F</i> <sub>o</sub> <sup>2</sup> + 2 <i>F</i> <sub>c</sub> <sup>2</sup> )/3	<i>w</i> = 1/[σ <sup>2</sup> ( <i>F</i> <sub>o</sub> <sup>2</sup> ) + (0.11 <i>P</i> ) <sup>2</sup> + 0.59 <i>P</i> ], where <i>P</i> = ( <i>F</i> <sub>o</sub> <sup>2</sup> + 2 <i>F</i> <sub>c</sub> <sup>2</sup> )/3	<i>w</i> = 1/[σ <sup>2</sup> ( <i>F</i> <sub>o</sub> <sup>2</sup> ) + (0.047 <i>P</i> ) <sup>2</sup> + 1.070 <i>P</i> ], where <i>P</i> = ( <i>F</i> <sub>o</sub> <sup>2</sup> + 2 <i>F</i> <sub>c</sub> <sup>2</sup> )/3
(Δ/σ) <sub>max</sub>	<0.0001	<0.0001	<0.0001	<0.0001
Δρ <sub>max</sub> , Δρ <sub>min</sub> (e Å <sup>-3</sup> )	0.23, -0.11	0.12, -0.15	0.14, -0.12	0.15, -0.19

Computer programs used: COLLECT software (Nonius, 1999), DENZO-SMN (Otwinowski & Minor, 1997), SCALEPACK (Otwinowski & Minor, 1997), SIR92 (Altomare *et al.*, 1994) in *maXus* (Mackay *et al.*, 1998); SHELXL97 (Sheldrick, 1997a), SHELXTL/PC (Sheldrick, 1990).

S,S crystals) that should be compared with the melting point of the racemic compound. The *T*<sub>eut</sub> value for the racemic conglomerate, which melts to give the same liquid as does the racemic compound, is estimated (see Brock *et al.*, 1991, and references therein) to be no higher than 380 K, *i.e.* at least 40 K lower than *T*<sub>fus</sub> for the racemic compound. At a temperature near 373 K (*i.e.* 100°C) a crystal of one of the enantiopure compounds has a substantially higher molar free energy than a crystal of the racemic compound, even though the enantiopure crystal is substantially denser. The first crystals that precipitate from a solution containing both enantio-

mers will be the racemic compound unless the mole fractions of the pure enantiomers are outside the range 0.13–0.87 (2).<sup>2</sup>

<sup>2</sup> Estimates of the eutectic temperature of the racemic conglomerate and of the composition above which enantiopure crystals are the first to precipitate depend weakly on the heats of fusion assumed. The eutectic temperature calculated for the racemic conglomerate is 380 K for Δ*H*<sub>fus</sub> = 32 kJ mol<sup>-1</sup> (a large value; see Jacques *et al.*, 1981) and decreases as Δ*H*<sub>fus</sub> is made smaller. The compositions of the *R,R*/*rac* and *S,S*/*rac* eutectics are 0.13 (2) and 0.87 (2) for all reasonable choices of Δ*H*<sub>fus</sub>. These estimates are probably affected more by the assumption of ideality than by the choices of the values for the heats of fusion.

The observed hydrogen-bonding motif, a dimer ribbon, is the same in the two structures, neither of which shows any important change (except reduction in the thermal motion) between 298 and 173 K. The presence of the dimer motif is somewhat surprising given the conflict between the restrictive hydrogen-bonding requirements of the 1,2-diol moiety (Brock, 2002) and the spatial requirements of the bulky cyclohexyl (or Cy) rings. The structure of the racemic compound is otherwise normal ( $C2/c$ ;  $Z' = 1$ ), except for the disorder in one Cy ring. The crystals of the enantiopure compound, however, have four molecules in the asymmetric unit ( $P2_1$ ,  $Z' = 4$ ). Such a large value is very rare in general

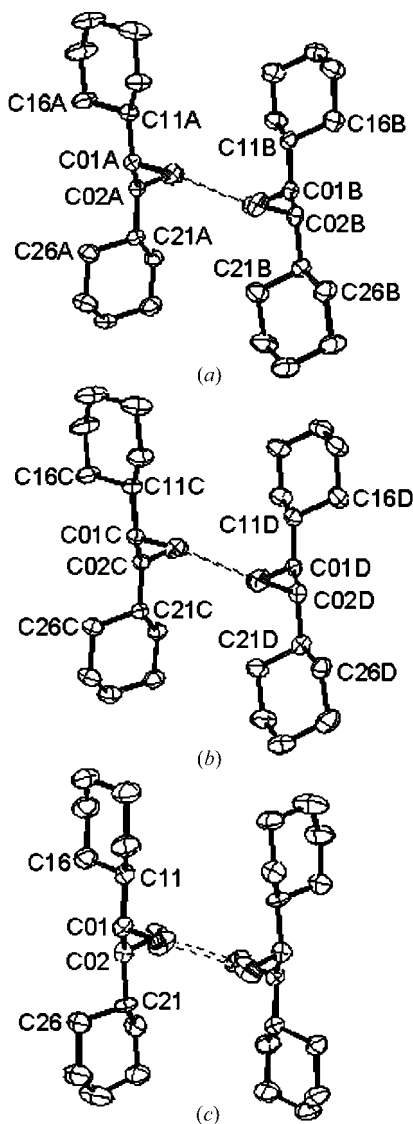

**Figure 1**  
(a) and (b) Ellipsoid plots (50% probability surfaces) showing the molecules of the  $Z' = 4$  structure, and (c) an inversion-related pair of molecules for the  $Z' = 1$  structure, all as determined at 173 K. The atom-numbering scheme, which is the same for all molecules, can be deduced from the information given; atoms without labels are numbered consecutively and O01 and O02 are bonded to C01 and C02. The H atoms have been omitted for clarity in this and the following drawings, as have one set of the disordered  $C2n$  atoms for the molecule of the  $Z' = 1$  structure.

**Table 2**  
Hydrogen-bond parameters ( $\text{\AA}$ ,  $^\circ$ ) as determined at 173 K.

Atoms	O—H	H···O	O···O	O—H···O
<i>Z'</i> = 4 structure				
Within dimers				
O02A—H02A···O01B	1.05 (5)	1.66 (5)	2.682 (3)	161 (4)
O02B—H02B···O01A	0.95 (4)	1.87 (4)	2.727 (3)	149 (3)
O02C—H02C···O01D	0.97 (4)	1.78 (4)	2.698 (3)	157 (3)
O02D—H02D···O01C	0.91 (5)	1.88 (5)	2.717 (3)	152 (4)
Average	0.97 (3)	1.80 (4)	2.706 (9)	155 (2)
Between dimers				
O01A—H01A···O02A <sup>i</sup>	0.90 (4)	1.83 (4)	2.724 (2)	170 (4)
O01B—H01B···O02B <sup>ii</sup>	0.95 (3)	1.72 (3)	2.656 (3)	169 (3)
O01C—H01C···O02C <sup>i</sup>	0.93 (4)	1.80 (4)	2.730 (2)	172 (3)
O01D—H01D···O02D <sup>ii</sup>	0.85 (3)	1.81 (3)	2.658 (3)	174 (3)
Average	0.91 (2)	1.79 (2)	2.692 (2)	171 (1)
<i>Z'</i> = 1 structure				
Within dimers <sup>†</sup>				
O01—H91B···O02	0.74 (2)	1.98 (3)	2.668 (2)	153 (4)
O02—H92B···O01 <sup>iii</sup>	0.72 (2)	1.95 (2)	2.668 (2)	173 (5)
Between dimers <sup>†</sup>				
O01—H91A···O01 <sup>iv</sup>	0.76 (2)	1.93 (2)	2.653 (2)	155 (3)
O02—H92A···O02 <sup>iv</sup>	0.84 (2)	1.81 (2)	2.636 (2)	166 (4)
Average	0.84 (2)	1.83 (2)	2.644 (3)	

Symmetry codes: (i)  $x+1, y, z$ ; (ii)  $x-1, y, z$ ; (iii)  $-x, -y+2, -z$ ; (iv)  $-x, y, -z+\frac{1}{2}$ . <sup>†</sup> The two sets of values within the dimer are for the two possible positions of the H atom in the same O···O bond. There are, however, two different O···O bonds between dimers, each of which lies on a twofold axis, which makes the distances and angles for the two possible H-atom positions the same.

(Brock & Dunitz, 1994; Steiner, 2000; Steed, 2003), although less so for alcohols (Brock & Duncan, 1994; Brock, 2002).

Analyses of these structures have made it possible to determine the level of aggregation (dimer formation; linking of dimers to form ribbons; three-dimensional packing of ribbons) at which the presence of the second enantiomer makes the overall packing more favorable. These analyses have led to a general observation about a difference in packing between enantiopure and racemic compounds.

## 2. Structure determinations

Data for the structure determinations of the enantiopure and racemic compounds at 295 K and at 173 K are given in Table 1. The H atoms attached to C atoms were placed in calculated positions and re-idealized after every least-squares cycle. The hydroxyl H atoms were found in difference maps and refined isotropically (see below). Information about the hydrogen bonds is given in Table 2. Perspective drawings of the molecular structures at 173 K are shown in Fig. 1 along with the atom-numbering schemes. The dimer ribbons and the packing are shown in Figs. 2–5. All other structural information has been deposited.<sup>3</sup> Details specific to the individual structures are given below.

<sup>3</sup> Supplementary data for this paper are available from the IUCr electronic archives (Reference: DE5024). Services for accessing these data are described at the back of the journal.

### 2.1. *S,S*-1,2-Dicyclohexylethane-1,2-diol

Crystals of enantiopure material provided by D. S. Matteson were used as received (see Hiscox & Matteson, 1996). The crystal was taken from a vial labeled as containing the *S,S* enantiomer. The crystals had grown as long needles, many of which were exceptionally fine. Faces belonged to the forms {010} and {001}. The melting point was found to be 403–408 K, which is in good agreement with the literature value (408–409 K) given by Hoffmann *et al.* (1989), who also gave the specific rotation for the *S,S* enantiomer.

Data collection and data processing were trouble free, even though **b** is exceptionally long and **a** is exceptionally short (ratio = 7.5). Data were collected at a crystal-to-detector distance of 50 mm. Unusual intensity patterns were found. The three  $h00$ ,  $h = 2n + 1$ , reflections within the  $\theta$  limits are all so weak as to seem to be absent, but  $\beta$  differs from  $90^\circ$  by more than  $0.3^\circ$  and there can be no  $2_1$  axis parallel to **a** in  $P2_1$ . The  $00l$ ,  $l$  even, reflections are about ten times weaker than the  $00l$ ,  $l$  odd, reflections. The  $h0l$ ,  $l$  odd and  $h + l$  odd, reflections are nearly twice as intense as the corresponding even

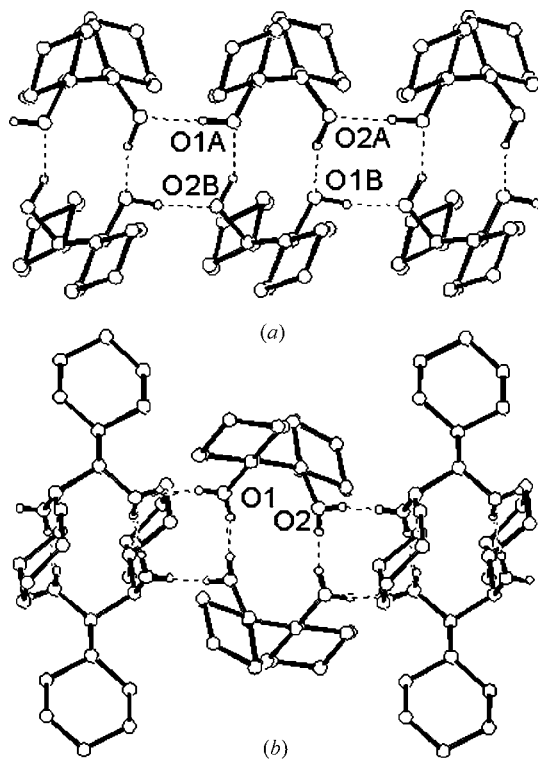

**Figure 2**

Projections of the ribbons of the *A* and *B* molecules of (a) the  $Z' = 4$  structure and (b) the  $Z' = 1$  structure drawn to maximize the similarity of the central dimers. The top drawing is rotated by  $25^\circ$  around the horizontal axis (**a**) from the plane of the O atoms. The bottom drawing is rotated by  $25^\circ$  around the horizontal axis (**e**) and by  $15^\circ$  around the vertical from the plane of the O atoms. Both sets of H positions for the  $Z' = 1$  structure are shown, but the second position of the C21–C26 ring is not. Only one of the two ribbons of the  $Z' = 4$  structure is shown because the two are essentially superimposable. Molecules in the  $Z' = 4$  structure (a) are related by translation only. Molecules in the  $Z' = 1$  structure (b) are related by inversion centers in the centers of the  $R_2^2(10)$  rings and by twofold axes that pass through the centers of the  $R_4^4(8)$  rings.

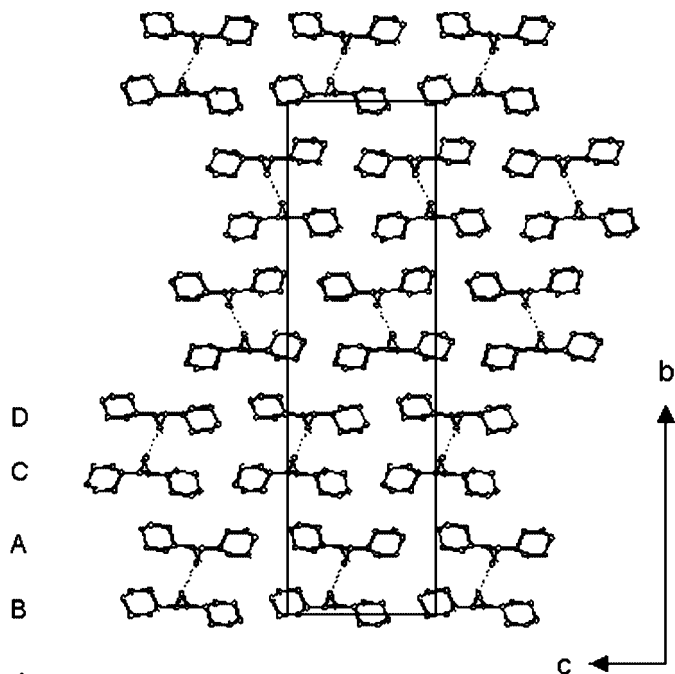

**Figure 3**

Projection of the  $Z' = 4$  structure as viewed along the **a** axis. The *x* coordinates of the centers of mass for the molecules shown are all in the range 0–1. The **c** axis is not quite in the plane of the drawing [ $\beta = 90.39(1)^\circ$  at 173 K].

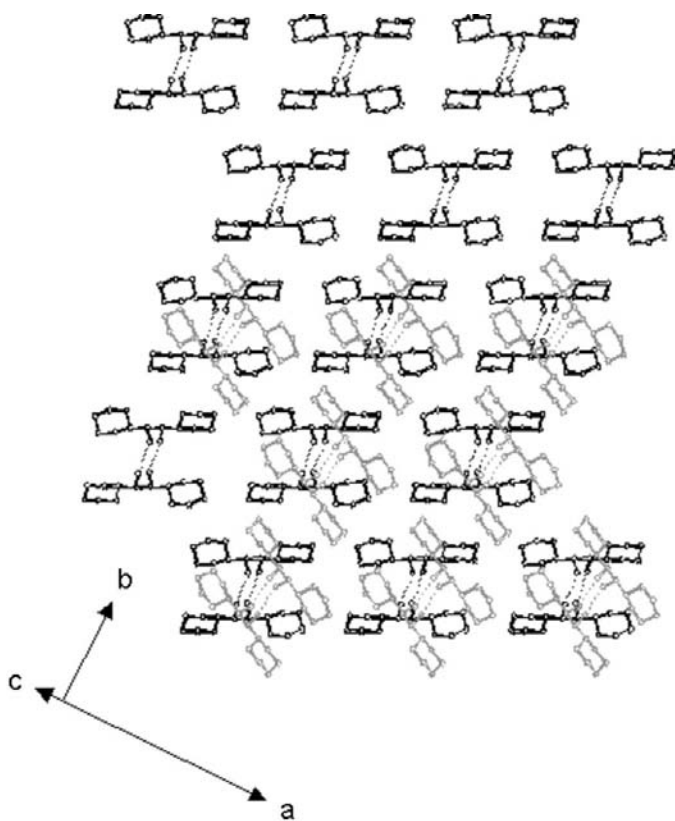

**Figure 4**

Projection of a slice of the  $Z' = 1$  structure ( $0.4 < z < 1.1$ ) viewed along  $c^*$ . The  $R_2^2(10)$  dimers near  $Z = 1$  have been darkened. The orientation and slice were chosen to maximize the similarity to the view shown of the  $Z' = 4$  structure in Fig. 3.

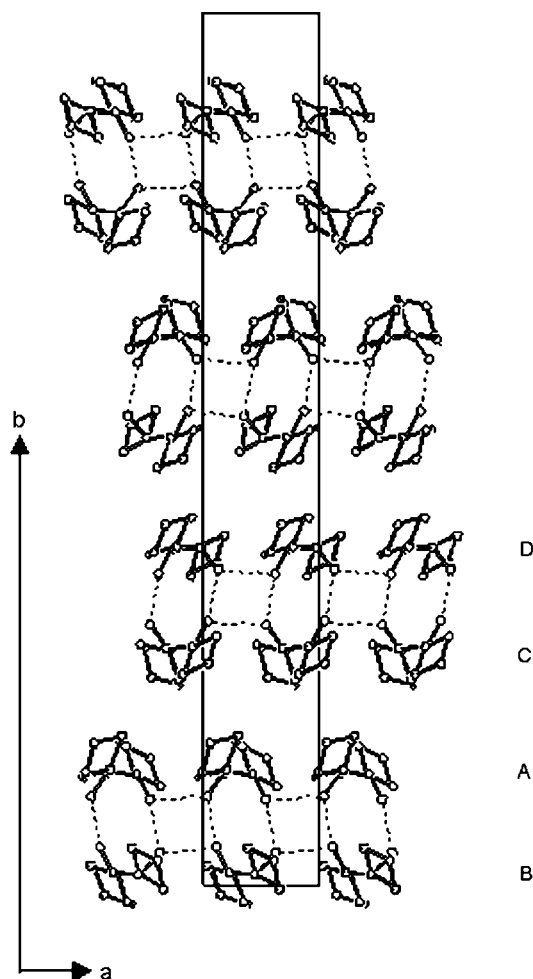

**Figure 5**  
Projection of the  $Z' = 4$  structure viewed along the  $c$  axis. The  $a$  axis is not quite in the plane of the drawing [ $\beta = 90.39(1)^\circ$  at 173 K].

reflections. There are strong pseudosymmetry relationships among the four independent molecules, but once solved, the structure was refined without difficulty.

Friedel reflections were merged because the  $\Delta f''$  values are so small; the designation  $S,S$  corresponds to the label on the bottle and to the coordinates refined. We saw no evidence in the difference maps for alternate H-atom positions, but the  $U_{\text{iso}}$  values for the hydroxyl H atoms are large enough [0.04 (1)–0.14 (2)  $\text{\AA}^2$  at 295 K; 0.041 (1)–0.12 (2)  $\text{\AA}^2$  at 173 K] to suggest disorder. The ‘single’ crystal studied at 295 K apparently included a small volume fraction [0.049 (2)] of a second individual that is related to the first by a twofold rotation around  $a$ . If the contribution from this second individual is removed the  $R1$  and  $wR2$  values rise from 0.056 and 0.144 to 0.063 and 0.165. No evidence of such twinning was found for the different crystal studied at 173 K.

## 2.2. *rac*-1,2-Dicyclohexylethane-1,2-diol

Crystals were grown by evaporation from ethanol solutions equimolar in the two pure enantiomers (provided in separate

vials by D. S. Matteson). The crystals grew as laths with larger {100} faces and smaller {010} faces. It was hard to manipulate a crystal without accidentally cleaving it parallel to the long axis (c). We saw no evidence for the presence of any other crystal form. The melting point was found to be 420 (1) K.

Initial refinement in the  $C2/c$  group (one independent molecule) resulted in displacement parameters for atoms C21–C26 of one Cy ring that were much larger than for the corresponding atoms C11–C16 of the other ring. The ellipsoids of atoms C21–C26 were elongated in directions approximately perpendicular to the average plane of the ring. A satisfactory disorder model was found for the low-temperature structure, although the model had to be highly restrained (SAME and DELU instructions; 60 restraints total) because the pairs of atoms are so close together (0.22–0.50  $\text{\AA}$ ). The occupancy factor converged to 0.52 (1); refinements of data collected at 173 K for two additional crystals gave values of 0.51 (2) and 0.50 (2). Difference maps for all three crystals indicated that the H atoms of the hydroxyl groups were each disordered over two positions with approximately equal occupancies. A check of interatomic H...H distances shorter than 2.40  $\text{\AA}$  turned up several contacts involving H atoms attached to C21A–C26A, C21B–C26B, O01 and O02 that suggested correlation between the disordered rings of adjacent molecules and between the disordered ring and the positions of the hydroxyl H atoms. All occupancy factors were therefore set to 0.5.

The  $C2/c$  space group of the low-temperature structure is probably only an approximation; the actual structure might have lower symmetry or a larger unit cell. Refinements in group  $Cc$  were, however, unsuccessful and we found no evidence of any additional Bragg or non-Bragg scattering. The data in the frames (80% of reflections observed on at least four different sets of frames) were transformed with the program *PRECESSION* (Nonius, 1999) to give undistorted views of slices  $nkl$ ,  $hnl$  and  $hkn$ ,  $n = 0-3$ , of the reciprocal lattice; careful inspections of these views revealed no unusual features.

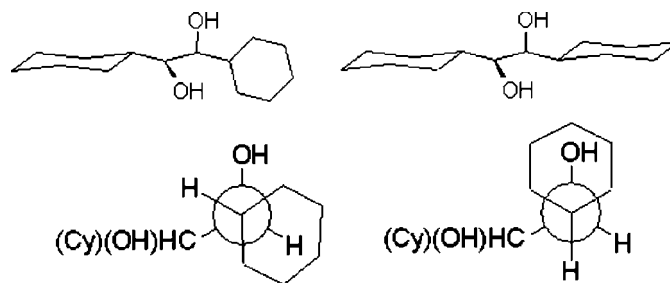

**Figure 6**  
Conformations of  $S,S$ -1,2-dicyclohexylethane-1,2-diol observed in the  $Z' = 4$  and  $Z' = 1$  structures are shown in the upper drawing; the cyclohexyl (or, Cy) ring containing the C21 $n$  atom is on the right-hand side of the drawing. Corresponding Newman projections down the C21 $n$ –C02 $n$  bonds are shown below. The conformation shown on the left is found for molecules  $A$  and  $C$  of the  $Z' = 4$  structure and for the one independent molecule of the  $Z' = 1$  structure. The conformation on the right is found for molecules  $B$  and  $D$  of the  $Z' = 4$  structure. The Newman projection shown on the left is the same as the projection down the C11 $n$ –C01 $n$  bond for all five molecules.

The four half-occupancy H atoms were refined isotropically with their bond lengths restrained to 0.86 (1) Å and with  $U_{\text{iso}}$  values 20% larger than those of the  $U_{\text{equiv}}$  values of the attached O atoms. If the *DFIX* restraint is removed one of the distances becomes very short (0.60 Å). The H-atom positions must be considered as approximate.

A similar disorder model could be refined for the data collected at 295 K [O—H distance restraint 0.84 (1) Å], although no model tried was completely satisfactory. For the low-temperature data *R1* and *wR2* are 0.047/0.118 and 0.052/0.139 for the models with and without disorder; for the room-temperature data the corresponding values are 0.068/0.208 and 0.074/0.221. The atomic displacements in the room-temperature structure are probably not modeled well by Gaussian distribution functions.

### 3. Analyses of the structures

#### 3.1. Overall hydrogen-bond pattern

Both structures are built (see Fig. 2) from one-dimensionally hydrogen-bonded dimer ribbons (Brock, 2002), which can also be described as ladders. In the  $Z' = 4$  structure (enantiopure material) the H atoms seem to be ordered, but in the  $Z' = 1$  structure (racemic compound) they are not (see above). For the  $Z' = 1$  structure there are three independent hydrogen bonds: the O01...O02 bond in the  $R_2^2(10)$  rings (notation of Bernstein *et al.*, 1995) located on inversion centers, and the O01...O01 and O02...O02 bonds in the  $R_4^4(8)$  rings located on twofold rotation axes (see Table 2). The basic hydrogen-bonding pattern is the same in the  $Z' = 4$  structure, but the components of the dimer are not related by any crystallographic symmetry. In the  $Z' = 4$  structure adjacent dimers are related by translation along the short **a** axis; there are eight independent hydrogen-bonded O...O distances.

In both structures all the molecules in a ladder rail are homochiral. In the  $Z' = 4$  structures there are two independent ladders (or ribbons) in the asymmetric unit, but the two independent dimers (and hence the two independent ribbons) are nearly superimposable; the *r.m.s.* deviation for 32 pairs of atoms calculated using routine *OFIT* of program *XP* (Sheldrick, 1990) is 0.049 Å. The two independent ribbons are related by an approximate  $2_1$  axis parallel to **a** (see Fig. 3 and below).

The hydrogen-bonding arrangement found for these structures is unusual for a *vic*-diol with bulky substituents (Brock, 2002). We found that physical models built from standard kits fell apart unless handled very carefully.

#### 3.2. Molecular conformations

The molecule of the  $Z' = 1$  structure, and molecules *A* and *C* of the  $Z' = 4$  structure have the conformation shown in the left side of Fig. 6; molecules *B* and *D* of the  $Z' = 4$  structure have the conformation shown on the right of the figure.

Simple molecular-mechanics minimizations were performed for all observed molecules using Version 2.1 of Duchamp's (2004) program *CrystMol*. The default force field was used.

Minimizations started from the crystallographic coordinates; the H-atom positions were adjusted first, then all atom positions were varied. The minimization process added an intramolecular O—H...O bond to each molecule, but changes in the overall conformations were small; the added bond should have little effect on the energy differences between conformers. Molecules *A* and *C* of the  $Z' = 4$  structure converged to one minimum and molecules *B* and *D* converged to another, with the conformational energy of the *A/C* minimum being lower by 5.5 kJ mol<sup>-1</sup>. The two disordered variants of the one crystallographically independent molecule of the  $Z' = 1$  structure converged to minima in which the torsion angles were similar to the torsion angles for the *A/C* minimum of the  $Z' = 4$  structure, but which have energies that are a little lower (0.6 and 2.3 kJ mol<sup>-1</sup>).

We considered doing other energy calculations, but concluded that small distinctions in energy could not be made in the absence of excellent information about the locations of the H atoms in the molecules as they occur in the crystals.

The O01—C01—C02—O02 torsion angle (60° for the idealized *S,S* enantiomer) is a little smaller in the  $Z' = 4$  structure than in the  $Z' = 1$  structure (see Table 3). The torsion angles O01—C01—C02—C21 and O02—C02—C01—C11 (see Fig. 6) are consequently somewhat larger in the  $Z' = 4$  structure [average 60.4 (8)°] than in the  $Z' = 1$  structure [average 50.6 (4)°].

The C11—C01—C02—C21 torsion angles are a little larger than 180° in the  $Z' = 4$  structure (see Table 3) with the C11 and C22 atoms rotated slightly towards the hydroxyl groups and a little smaller than 180° in the  $Z' = 1$  structure. While the *anti* arrangement found here for the Cy substituents was antici-

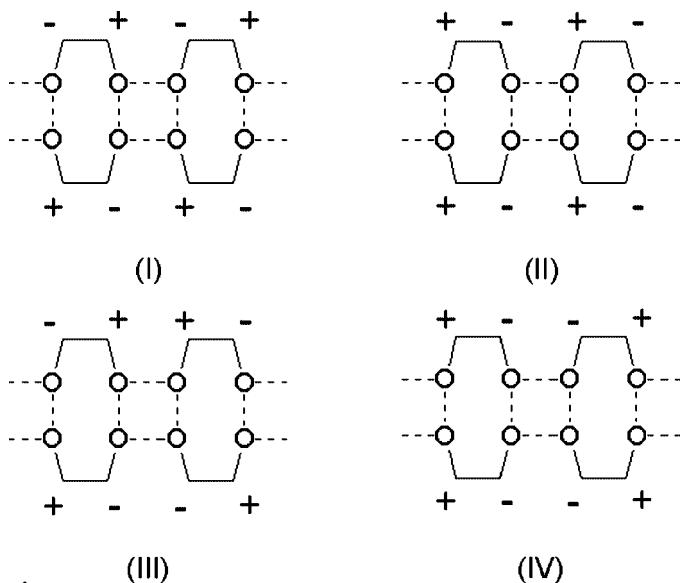

Figure 7

Types of hydrogen-bonded ribbons possible for *vic*-diols. The symbols + and - denote atomic displacements above and below the plane of the drawing. The molecules that form a dimer are homochiral in ribbon types I and III, and heterochiral in ribbon types II and IV. Molecules in the same rail are homochiral in ribbon types I and II, and heterochiral in types III and IV.

**Table 3**

 Selected torsion angles ( $^{\circ}$ ) at 173 K.

 The values for the  $Z' = 4$  structure are listed in order for molecules *A*, *B*, *C* and *D*. For the  $Z' = 1$  structure the value for the site with the higher occupancy is listed first.

	$Z' = 4$ structure	$Z' = 1$ structure
O01–C01–C02–O01	–63.0 (2); –65.2 (2); –62.3 (3); –65.5 (3)	–73.2 (1)
C11–C01–C02–C21	185.8 (2); 184.3 (2); 185.8 (2); 183.2 (2)	175.8 (5); 173.3 (5)

pated, there is also precedent for a *gauche* arrangement. A search of the Cambridge Structural Database (hereafter the CSD; Allen, 2002) located two simple structures (MDCMHX; Beckhaus *et al.*, 1978; YATDUS; Koh *et al.*, 1993) in which the Cy–C–C–Cy torsion angle is less than  $60^{\circ}$ .

### 3.3. Dimer formation

We found no indication of any important energy difference between the enantiopure and racemic dimers [hydrogen-bond motif  $R_2^2(10)$ ]. There are small differences in the hydrogen-bond distances and angles (see Table 2) and O–C–C–O torsion angles (see above), but there is no obvious steric problem. Examination of space-filling representations calculated with the program *Mercury* (Bruno *et al.*, 2002) shows that there are no short contacts within the dimers and that there would be no short contacts in a dimer formed from two homochiral molecules both having the conformation found for molecules *A* and *C* of the  $Z' = 4$  structure. The bulky Cy substituents are actually farther apart in the  $Z' = 4$  structure (see Fig. 7) than in the  $Z' = 1$  structure.

In both structures the dimers have approximate  $C_2$  symmetry along the chain axis (see Fig. 1). In both structures the four O atoms in a dimer are at least roughly coplanar [*r.m.s.* deviations are 0.035 (1) and 0.041 (1) Å in the  $Z' = 4$  structure and 0.155 (2) Å in the  $Z' = 1$  structure]. As can be seen in Fig. 1, the Cy rings are mostly slightly tilted away from the region of the O–H...O bonds.

### 3.4. Linking of dimers to form ribbons

We find no obvious steric problem resulting from the linking together of the dimers through hydrogen bonds having the  $R_4^4(8)$  pattern. In each ladder rail the Cy rings lie alternately above and below the O-atom plane and so do not interfere. Space-filling representations (program *MERCURY*; Bruno *et al.*, 2002; van der Waals radii from Bondi, 1964) suggest that the Cy rings within a ribbon do not quite ‘touch’.

Dimer ribbons formed from the HO–C–C–OH unit with torsion angles O–C–C–O *ca*  $60^{\circ}$  can have four different arrangements (see Fig. 7). In ribbon types I and II the molecules adjacent in one ladder rail can be related by translation; in ribbon types III and IV adjacent molecules must be related by some improper symmetry operation (*e.g.* a glide plane) unless they are crystallographically independent. The mole-

cules that form a dimer are homochiral in ribbon types I and II, and heterochiral in types III and IV. Ribbon type I is the only possibility for an enantiomerically pure crystal.

Measurements of physical models built from HO–C–C–OH units suggest that ribbon types III and IV are *ca* 5–10% shorter per dimer unit than ribbon types I and II. The greater extension of ribbon types I and II, which are also substantially flatter than types III and IV, would be expected to be advantageous in the case of bulky substituents, and it is these types that are found in these structures. A physical model for ribbon type II, which is found in the racemic  $Z' = 1$  structure, lies flat, but a model for ribbon type I, which is the only

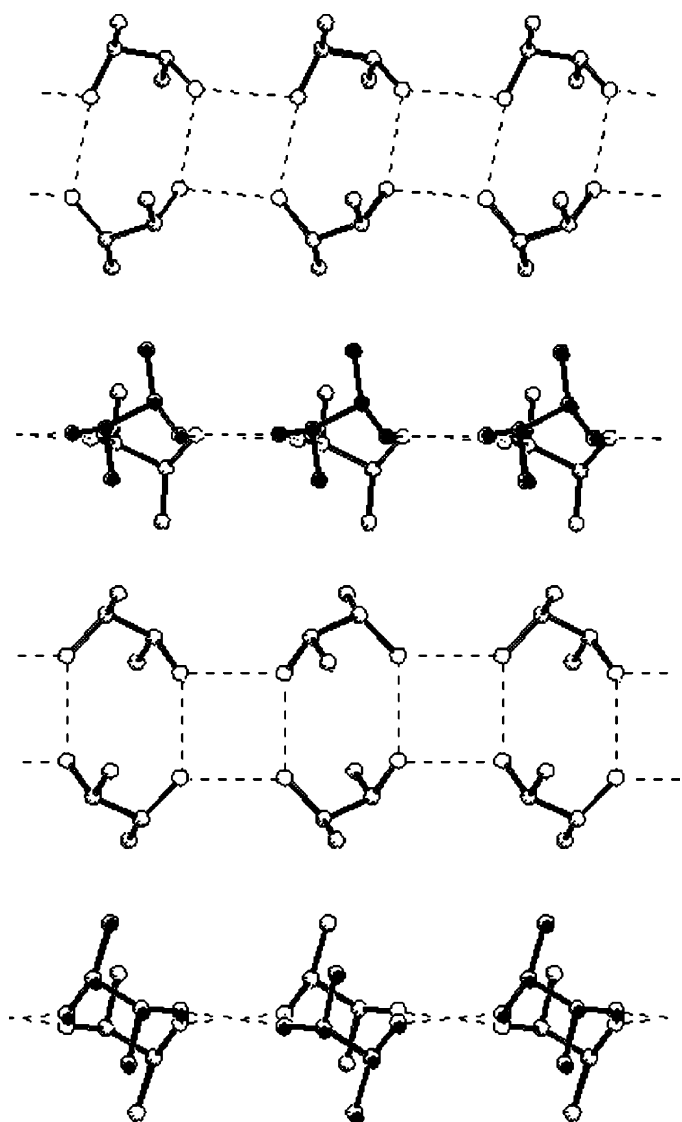

**Figure 8**  
Two views each of the hydrogen-bonded dimer ribbons found in the structures having  $Z' = 4$  (upper pair) and  $Z' = 1$  (lower pair). Only the C11 and C21 atoms of the cyclohexyl groups are shown. For the upper drawing of each pair the view is perpendicular to the least-squares plane of the O atoms. The upper and lower drawings of each pair are related by a  $90^{\circ}$  rotation around the horizontal. Only one of the two dimer ribbons of the  $Z' = 4$  structure is shown because the two ribbons are essentially superimposable. Where the molecules overlap the one in front has been darkened.

**Table 4**

Comparison of packing in the two structure types.

	$Z' = 4$ structure	$Z' = 1$ structure	Ratio ( $Z' = 4/Z' = 1$ )
At 173 K			
$V$ per dimer ( <i>i.e.</i> $2V/Z$ ) (Å <sup>3</sup> )	675.2 (2)	707.2 (3)	0.956
Repeat distance along hydrogen-bonded chains (Å)	$a = 5.482$ (1)	$(c \sin b)/2 = 5.271$ (1)	1.040
Other repeat distance within layer (Å)	$c = 11.954$ (2)	$(a^2 + b^2)^{1/2}/2 = 12.948$ (6)	0.923
Distance between layers (Å)	$b/4 = 10.316$ (2)	$[a^2 + (-4b)^2]^{1/2}/5 = 10.360$ (6)	0.996
At 295 K			
$V$ per dimer ( <i>i.e.</i> $2V/Z$ ) (Å <sup>3</sup> )	693.7 (2)	725.2 (3)	0.957
Repeat distance along hydrogen-bonded chains (Å)	$a = 5.540$ (1)	$(c \sin b)/2 = 5.286$ (1)	1.048
Other repeat distance within layer (Å)	$c = 12.025$ (2)	$(a^2 + b^2)^{1/2}/2 = 13.005$ (6)	0.925
Distance between layers (Å)	$b/4 = 10.413$ (2)	$[a^2 + (-4b)^2]^{1/2}/5 = 10.552$ (6)	0.987

possibility for the  $Z' = 4$  structure, is twisted [*ca* nine  $R_2^2(10)$  units per turn] unless the  $R_4^4(8)$  rings are forced to be planar. The energy cost of making ribbon type I lie flat may partially account for the low melting point of the enantiopure compound.

It seems that the ladder (or dimer-ribbon) motifs actually observed in these two structures are even more strained than simple models predict. In both structures (see Fig. 8) one of the two C atoms of each ethylene chain is much farther than the other (*ca* 0.8–0.9 Å *versus* 0.1–0.2 Å) from the least-squares plane of the O atoms of the dimer ribbon. We found it impossible to force models made from standard kits to reproduce the observed features.

Strain is also apparent in the C—O···O angles, which would be *ca* 90–110° if the C—O—H angles were normal and the O—H···O angles were 180°. These C—O···O angles are 119, 131, 118, 132, 112, 113, 112 and 113° in the  $Z' = 4$  structure, and 136, 135, 134 and 121° in the  $Z' = 1$  structure (all individual e.s.d.s < 0.2°). These angles suggest there is less angular strain in the dimer ribbon of the enantiopure  $Z' = 4$  structure than in the dimer ribbon of the racemic  $Z' = 1$  structure.

The O···O distances in the  $Z' = 4$  structure are just slightly longer (*ca* 0.04 Å) than in the  $Z' = 1$  structure (see Table 2).

In the  $Z' = 4$  structure the molecules in a ladder rail all have the same conformation, but the conformations of the molecules in the two ladder rails are different. This segregation suggests that the higher-energy conformation occurs not because it makes the interactions within the ribbons more favorable but because it makes the packing of the ribbons more favorable.

### 3.5. Packing of the dimer ribbons

The crystal habits indicate (as expected) that growth is fastest along the hydrogen-bonded ribbon, especially in the  $Z' = 4$  structure. The packings of the dimer ribbons in the two structures are similar, as can be seen from Figs. 2–4 and Table 4.

Table 4 shows that the chain length per dimer is somewhat shorter in the  $Z' = 1$  structure. The greater density of the  $Z' = 4$  structure seems to be a result of more efficient packing in its  $c$  direction (see Fig. 3). The corresponding direction in the  $Z' = 1$  structure is approximately  $(\mathbf{a} + \mathbf{b})/2$  (see Fig. 4).

Packing efficiencies in the third interlayer directions, which are the long  $\mathbf{b}$  axis of the  $Z' = 4$  structure and the  $\mathbf{a} - 4\mathbf{b}$  direction of the  $Z' = 1$  structure, are about the same.

The two kinds of dimer ribbons have different profiles (see Figs. 2–4). In the  $Z' = 4$  structure all  $R_2^2(10)$  dimers are related by translation and so all have the same orientation; the van der Waals surface is quite smooth. In the  $Z' = 1$  structure, however, adjacent dimers are rotated so that the chain profile has much more relief.

The fineness of the  $Z' = 4$  needles and the easy cleavage of the  $Z' = 1$  laths indicate that the interactions between dimer ribbons are weak in both structures. The van der Waals profiles of most of the molecules (see Figs. 1, 3 and 4) are indented near the plane of the O atoms. These concave molecular surfaces make the filling of space by symmetry related molecules more difficult.

### 3.6. Pseudosymmetry in the $Z' = 4$ structure

The  $P2_1$ ,  $Z' = 4$  structure ( $\beta = 90.3^\circ$  at 295 K) can be viewed as a perturbed version of a  $P2_12_12_1$ ,  $Z' = 2$  structure. Comparisons are made most easily if the origin is first shifted by  $\Delta y = 0.05$  (because the origin of  $y$  is arbitrary) and  $\Delta z = -0.25$  (because the  $z$  coordinates of the  $2_1$  axes parallel to  $\mathbf{b}$  in the standard settings of  $P2_1$  and  $P2_12_12_1$  differ by  $\frac{1}{4}$ ). Molecules are then related by approximate  $2_1$  axes parallel to  $\mathbf{c}$ ; the translation is  $\Delta z = \frac{1}{2} \pm 0.070$  (2) [where 0.070 (2) corresponds to 0.84 (2) Å] and the axes are located at  $x = -\frac{1}{4} - 0.002$  (3) and  $y = \frac{1}{2} + 0.000$  (1). Molecules related by the approximate  $2_1$  axes parallel to  $\mathbf{a}$  are separated by  $\Delta x = \frac{1}{2} \pm 0.005$  (7), and the axes are located at  $y = \frac{1}{4} + 0.000$  (3) and  $z = -\frac{1}{4} + 0.035$  (1) [where 0.035 (1) corresponds to 0.42 (1) Å]. The primary effect of the symmetry-lowering perturbation is to change the contacts across the plane containing the  $2_1$  axes that would be parallel to  $\mathbf{c}$  in  $P2_12_12_1$ . Structures in  $P2_12_12_1$  generated from molecule pairs  $A/B$  or  $C/D$  have intermolecular H···H contacts as short as 1.9 Å and intermolecular C···H contacts as short as 2.0 Å.

The origin of the symmetry lowering is probably the mismatch between the distance along  $\mathbf{c}$  (see Fig. 3) between the centers of Cy rings in the same molecule and between centers of Cy rings of different molecules that are adjacent along  $\mathbf{c}$ . (The distances between these rings along  $\mathbf{b}$  are not



large; see Fig. 5.) For the ring centers within a molecule  $\Delta z$  is 0.544 (10) (average for four molecules); the corresponding intermolecular separation between adjacent ring centers is 0.456 (10). If the pseudo  $2_1$  axis along  $\mathbf{c}$  were real then molecules related by the translation  $\mathbf{c}$  would have to be farther apart, which means that the packing would be less dense.

The intensities of the three  $h00$ ,  $h$  odd, reflections measured are essentially zero, as is expected given the translations of 0.505/0.495 (7) associated with the pseudo  $2_1$  axes parallel to  $\mathbf{a}$ . The average intensity of the seven  $00\ell$ ,  $\ell$  odd, reflections is, however, large because the translations associated with the pseudo  $2_1$  axes parallel  $\mathbf{c}$  differ significantly from  $\frac{1}{2}$  [ $\pm 0.070$  (2)].

The small size of the change in the  $\beta$  angle between 173 and 295 K [from 90.39 (1) to 90.33 (1) $^\circ$ ] suggests that no phase transition from  $P2_1$  to  $P2_12_12_1$  occurs below the melting point (408–409 K). No indication of any phase transition was seen when the melting point was measured.

### 3.7. Energy balance

The comparison of the estimated eutectic temperature for the racemic conglomerate of the  $Z' = 4$  crystals (half the crystals containing  $S,S$  molecules and the other half containing  $R,R$  molecules) with the melting point of the  $Z' = 1$  crystals of the racemic compound shows that the latter are substantially more stable at *ca* 373 K even though they are also more than 4% less dense and even though greater density is normally associated with more favorable packing. The racemic compound dominates the two-component  $T$ – $X$  phase diagram for  $R,R$ - and  $S,S$ -1,2-dicyclohexylethane-1,2-diol.

The  $Z' = 4$  structure may be favored by its greater density, but its energy is raised by the unfavorable conformation (see Fig. 6) adopted by two of the eight Cy substituents. Its energy is also raised because the hydrogen-bonded dimer ribbons are forced by the translation symmetry to lie flat rather than being allowed to twist into long-period helices. These three factors (the one that favors the  $Z' = 4$  structure and the two that favor the  $Z' = 1$  structure) probably account for most of the stability difference between the two structures. The observed  $Z' = 4$  structure may be the best possible structure for the enantiopure material, but it is still a compromise (as the high  $Z'$  value suggests). If the mole fraction (and hence the activity) of one enantiomer is not at least 0.87 (2), then precipitation of the racemic compound is more favorable than precipitation of enantiopure crystals.

The  $Z' = 1$  structure is stabilized, at least in principle, by  $T\Delta S$  terms associated with the disorder and with the somewhat greater thermal motion. That disorder term, however, is probably not as large as  $RT\ln 2$  ( $= kT\ln 2^N$ , where  $N$  is Avogadro's number) = 2.1 kJ mol $^{-1}$  at 373 K, because the disorder seems not to be random. The difference  $T\Delta S_{\text{vib}}$  between the two structures is not expected to be large either because  $S_{\text{vib}}$  changes relatively slowly with vibrational amplitudes and because the  $U_{\text{iso}}$  values for the two structures are not very different.

### 3.8. Related structures

Searches of the CSD for related structures located seven simple, symmetrical dihydrobenzoin derivatives (Pennington *et al.*, 1988; Karlsson *et al.*, 1990; Swift *et al.*, 1998), but six of them are  $R,S$  (or *meso*) molecules. In the one  $R,R$  structure ( $R,R$ -dihydrobenzoin; Pennington *et al.*, 1988; refcode VABVAV) each O atom participates in only one O–H...O bond. We looked at crystals of *rac*-dihydrobenzoin and suspect we are not the first to have found that the crystals are both very small and twinned. It may be that simple  $R,R$  and  $S,S$  dihydrobenzoins cannot form dimer ribbons because the phenyl rings are not large enough to fill the space above and below the plane of the O atoms, but are too large to allow interleaving of rings from adjacent ribbons.

The dimer ribbon pattern found in the structures reported here was also found for *rac*-2,3-diphenyl-2,3-butanediol (BUHDAJ; Fronczek *et al.*, 1982), but in that structure the ribbon twists around a  $4_2$  axis so that adjacent dimers are perpendicular.

## 4. Discussion

These two structures illustrate an important difference, perhaps the most important difference, between structures of molecules that can and cannot crystallize in space groups that include improper symmetry operations. When all the *vic*-diol molecules in a dimer ribbon are homochiral, then the orientations of adjacent dimers must be related by a rotation of  $360^\circ/n$ , where  $n$  is 1, 2, 3, 4 or 6, unless the dimers are crystallographically independent (*i.e.*  $Z' > 1$ ). This requirement greatly restricts the number of possible packing arrangements. On the other hand, if improper symmetry operations are allowed then the orientations of adjacent dimers may be related by an improper rotation of arbitrary magnitude, because a second application of an inversion or glide operation restores the original orientation and the first and third dimers are related by translation.

This packing requirement applies to any pair of adjacent molecules in any enantiopure crystal, whether or not the molecules are linked by hydrogen bonding. The requirement applies to all three dimensions.

It seems likely that this important restriction on possible packing arrangements accounts for the relatively low fraction of achiral molecules and racemic compounds that crystallize in proper space groups (no inversion centers, glide planes or improper rotation axes). Less than 20% of all structures in the CSD are described by proper space groups and many (perhaps even most) of those structures were determined for crystals grown from enantiopure material. It has been estimated (Brock *et al.*, 1991) that molecules and compounds that can crystallize in improper space groups have at least a 90% probability of doing so, primarily because of 'the additional possibilities for favorable packing arrangements available in racemic space groups'.

This packing problem probably also accounts for the relatively high fraction of enantiopure compounds that crystallize

with  $Z' > 1$  (Brock & Dunitz, 1994; Steiner, 2000; Steed, 2003). The presence of at least one additional packing unit means that the orientations of at least some adjacent molecules can be related by rotations of arbitrary magnitude.

We are very grateful to Professor D. S. Matteson of Washington State University for providing samples of both *R,R*- and *S,S*-1,2-dicyclohexylethane-1,2-diol.

## References

- Allen, F. H. (2002). *Acta Cryst.* **B58**, 380–388.
- Altomare, A., Cascarano, G., Giacovazzo, C., Guagliardi, A., Burla, M. C., Polidori, G. & Camalli, M. (1994). *J. Appl. Cryst.* **27**, 435–436.
- Beckhaus, H.-D., Hellmann, G., Ruechardt, C., Kitschke, B. & Lindner, H. J. (1978). *Chem. Ber.* **111**, 3764–3779.
- Bernstein, J., Davis, R. E., Shimon, L. & Chang, N.-L. (1995). *Angew. Chem. Int. Ed. Engl.* **34**, 1555–1573.
- Bondi, A. (1964). *J. Phys. Chem.* **68**, 441–451.
- Brock, C. P. (2002). *Acta Cryst.* **B58**, 1025–1031.
- Brock, C. P. & Duncan, L. L. (1994). *Chem. Mater.* **6**, 1307–1312.
- Brock, C. P. & Dunitz, J. D. (1994). *Chem. Mater.* **6**, 1118–1127.
- Brock, C. P., Schweizer, W. B. & Dunitz, J. D. (1991). *J. Am. Chem. Soc.* **113**, 9811–9820.
- Bruno, I. J., Cole, J. C., Edgington, P. R., Kessler, M., Macrae, C. F., McCabe, P., Pearson, J. & Taylor, R. (2002). *Acta Cryst.* **B58**, 389–397.
- Duchamp, D. J. (2004). *CrystMol*, Version 2.1. D&A Consulting LLC, Kalamazoo, Michigan, USA.
- Flack, H. D. (2003). *Helv. Chim. Acta*, **806**, 905–921.
- Fronczek, F. R., Oliver, M. A. & Gandour, R. D. (1982). *Cryst. Struct. Commun.* **11**, 1965–1969.
- Hiscox, W. C. & Matteson, D. S. (1996). *J. Org. Chem.* **61**, 8315–8316.
- Hoffmann, R. W., Ditrich, K., Koester, G. & Stuermer, R. (1989). *Chem. Ber.* **122**, 1783–1789.
- Jacques, J., Collet, A. & Wilen, S. H. (1981). *Enantiomers, Racemates, and Resolutions*. New York: John Wiley and Sons.
- Karlsson, O., Lundquist, K. & Stomberg, R. (1990). *Acta Chem. Scand.* **44**, 617–624.
- Kipping, F. S. & Pope, W. J. (1897). *J. Chem. Soc. Trans.* **71**, 989–1001.
- Koh, L. L., Tan, E. H., Xu, Y., Lee, S. Y., Lam, Y. L. & Huang, H. H. (1993). *J. Chem. Res. Syn.*, pp. 294–295.
- Mackay, S., Gilmore, C. J., Edwards, C., Tremayne, M., Stuart, N. & Shankland, K. (1998). *maXus*. University of Glasgow, Scotland, Nonius BV, Delft, The Netherlands, MacScience Co. Ltd, Yokohama, Japan.
- Nonius (1999). *COLLECT*. Nonius BV, Delft, The Netherlands.
- Otwinowski, Z. & Minor, W. (1997). *Methods Enzymol.* **276**, 307–326.
- Pennington, W. T., Chakraborty, S., Paul, I. C. & Curtin, D. Y. (1988). *J. Am. Chem. Soc.* **110**, 6498–6504.
- Sheldrick, G. M. (1990). *SHELXL/PC*. Siemens Analytical Instruments, Inc., Madison, Wisconsin, USA.
- Sheldrick, G. M. (1997a). *SHELXL97*. University of Göttingen, Germany.
- Steed, J. W. (2003). *CrystEngComm*, **5**, 169–179.
- Steiner, T. (2000). *Acta Cryst.* **B56**, 673–676.
- Swift, J. A., Pal, R. & McBride, J. M. (1998). *J. Am. Chem. Soc.* **120**, 96–104.
- Wallach, O. (1895). *Liebigs Ann. Chem.* **286**, 90–143.